

oslo

curtain automation

SERIES 81

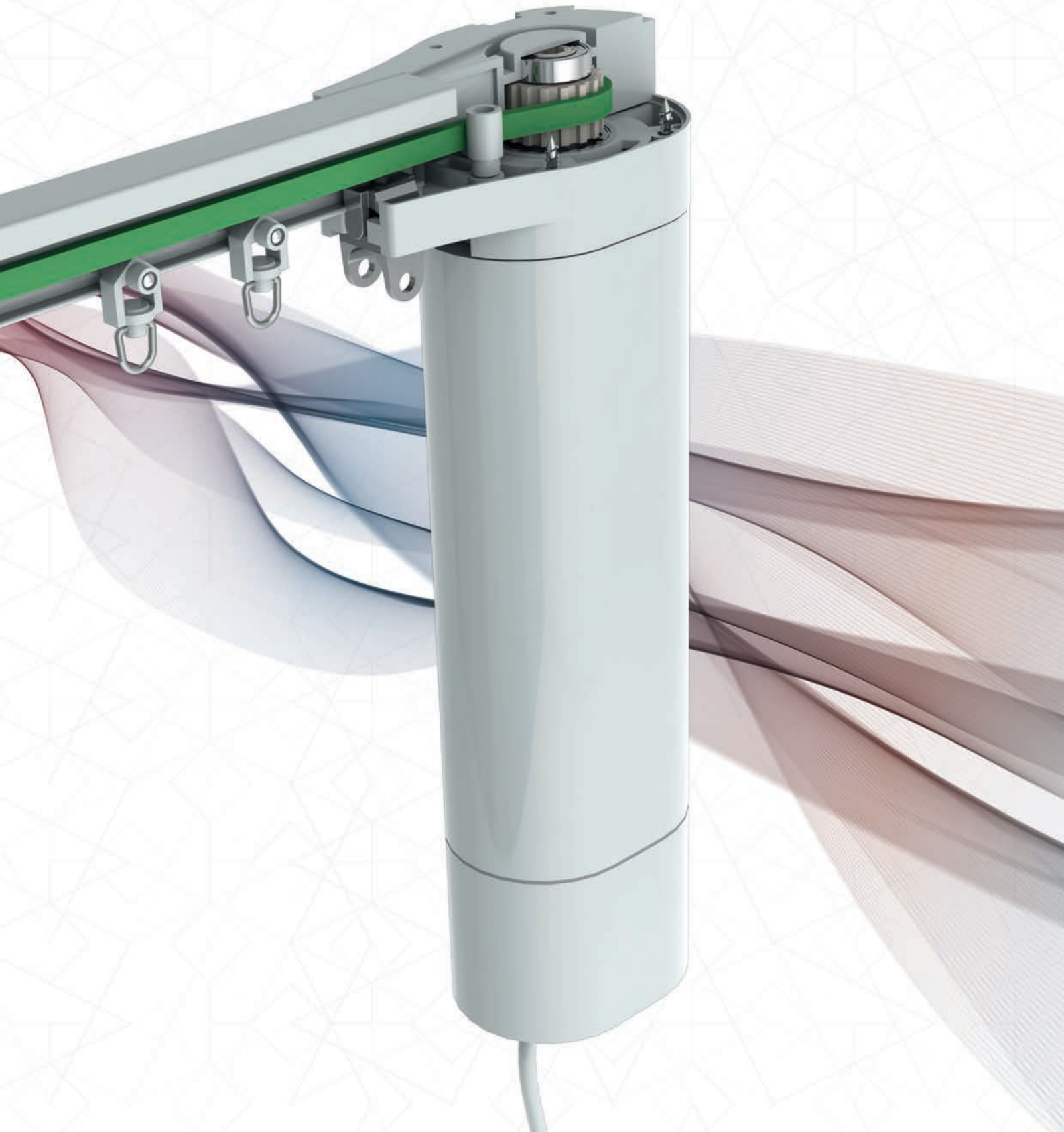

OSLO Series 81

TURBO MOTORISED TRACK SYSTEM

Delivering innovative technology and an adaptable track system, Series 81 is the pinnacle in motorised curtain design.

Features

- Smallest motorised track system available on the market
- Driven by the powerful 75W Oslo motor as used on Series 84
- Smooth and quiet operation featuring the kevlar impregnated belt
- Track size only 17mm x 25mm
- Uses attractive Easy-Clip bracket system not visible from the front of the track
- Range of projections (40mm, 70mm, 115mm, 160mm) for face fix brackets with covers to conceal the screws
- Pulley/drive units have metal bearings for long-life, smooth operation
- Unique track design can be easily curved to a radius as tight as 150mm
- Suits S-Wave and conventional curtains
- Fully automatic setting of electrical limits
- Unique touch start feature - gently pulling the curtain will activate the motor
- Manual operation possible during power outages
- Inbuilt receiver compatible with a range of transmitters
- 5 year warranty on motor
- Operating speed 20cm per second

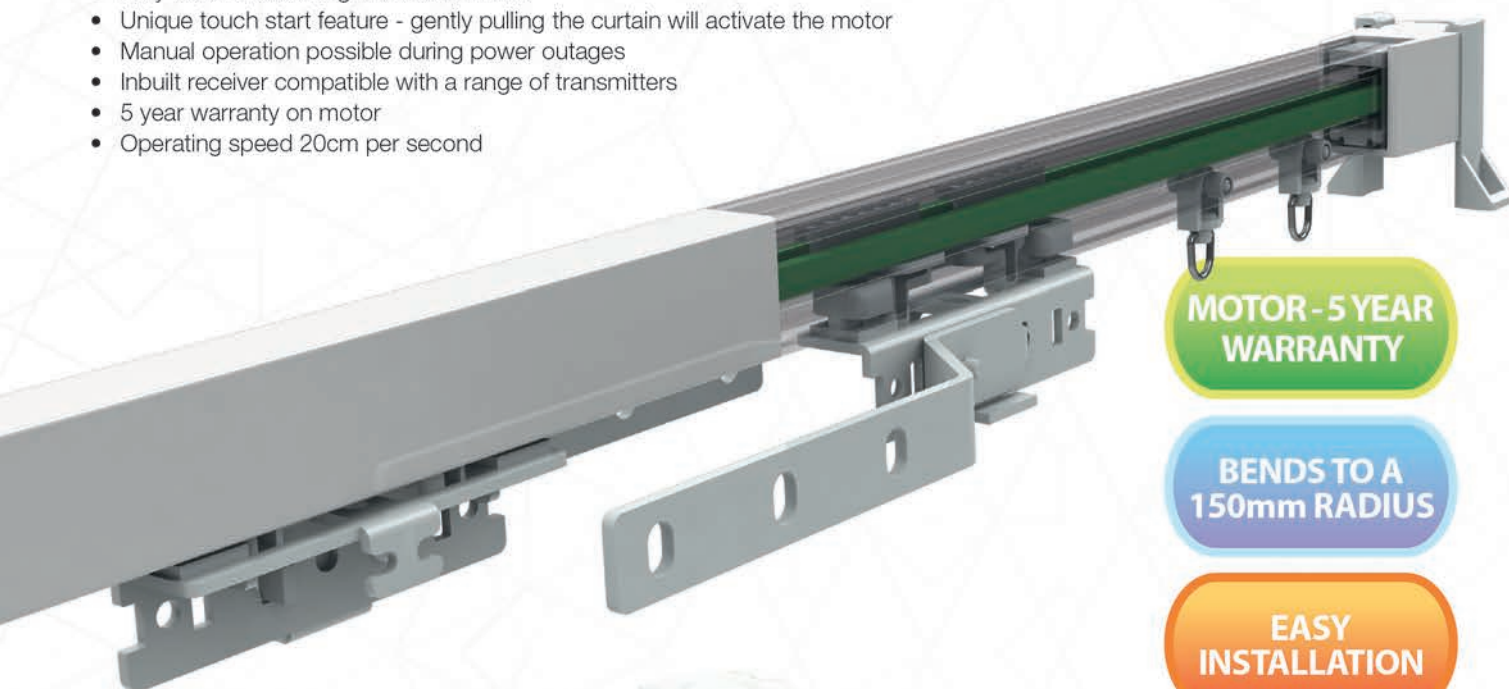

MOTOR - 5 YEAR WARRANTY

BENDS TO A 150mm RADIUS

EASY INSTALLATION

Straight or curved track

Both straight track and curved track are available to suit various applications and requirements.



Straight Track



Curved Track



Track Curve | min. 150mm radius



4-Core Curtain Motor

8402 - 100kg Curtain Motor 4-Core

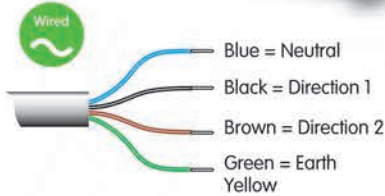

4-Core Motor

These motors can be used with building automation systems such as C-BUS and Dynalite etc.

3-Core

8401 - 100kg Curtain Motor with built in receiver

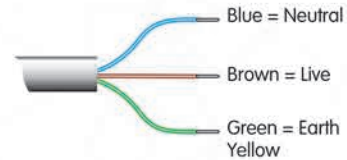

3-Core Motor

The built in receiver means these motors can be used with a range of controllers

Technical Information

Specifications	8402 4-Core & 8401 3-Core
Rated Curtain Weight	100 Kilograms
Rated Input Power	75 Watts
Open/close Speed	20 (cm/sec)
Input Rated Voltage	230 Volts
Frequency	50 Hertz
Rated Current	0.34 Amps
Running Time	4 Minutes
Protection Class	IP20
Maximum Range of Revolutions	∞
Motor Weight	1.1 Kilograms

Motor Buttons

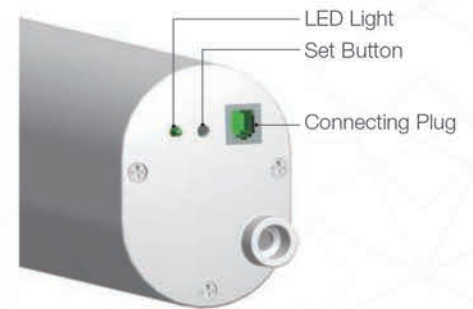

Track & Motor Dimensions

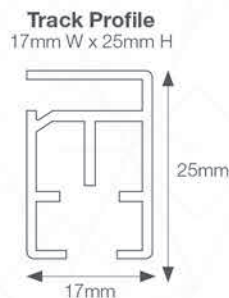

Single Motor Installation

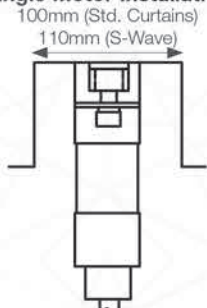

Multiple Motor Installation

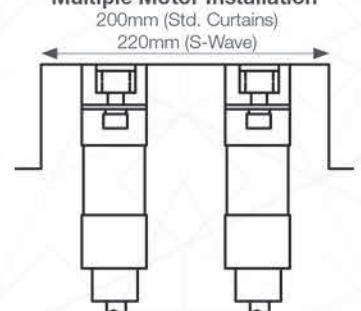

OSLO Series 81/84 Control System Solutions

Connect the Oslo Series 81/84 motors to a home/office automation system or use one the many elegant remote controls to manage the comfort of your rooms. The range of remote controls are designed to be easy to use and functional, whilst remaining discrete and attractive to suit any décor.

Hand Held & Wall Mounted Radio Remote Solutions

- Specialty Curtain Motor Controller
- Double controller will operate both the sheer and block out curtains
- Each channel can control up to 20 receivers
- Battery usage life > 3 years
- Transmitter range: Outdoor 200 meters, indoor 35 meters
- Controller frequency: 433.92 MHz ± 100KHz
- Controller power: 10mW -



Europe CE certificate



Europe wireless emission frequency certificate



ISO9001 quality management system certificate



ISO14000 environment management system certificate

Please note: Not all states carry the same product range.

Queensland

2/6 Nestor Drive
Meadowbrook QLD 4131
T 07 3200 4133
E sales@osloqld.com.au

Victoria

4/1 Rimfire Drive
Hallam VIC 3803
T 03 9703 1155
E trackco@tpg.com.au

South Australia

11/22 Ware Street
Thebarton SA 5031
T 08 8352 7688
E ijs@m2data.com.au

New Zealand

18 Darragh Road, Feilding
T +64 6 353 0444
E david@oslo.co.nz

New South Wales

9/19 Chifley Street
Smithfield NSW 2164
T 02 9725 5277
E info@oslonsw.com.au

Tasmania

55 Lampton Avenue
Moonah TAS 7009
T 03 6272 3400
E helen.armstrong@sanptyltd.com

Western Australia

3/17 Gibberd Road
Balcatta WA 6021
T 08 9240 1234
E orders@traxwest.com.au

oslo
curtain hardware

